

HOISTWAY PLAN
WITHOUT CWT SAFETY

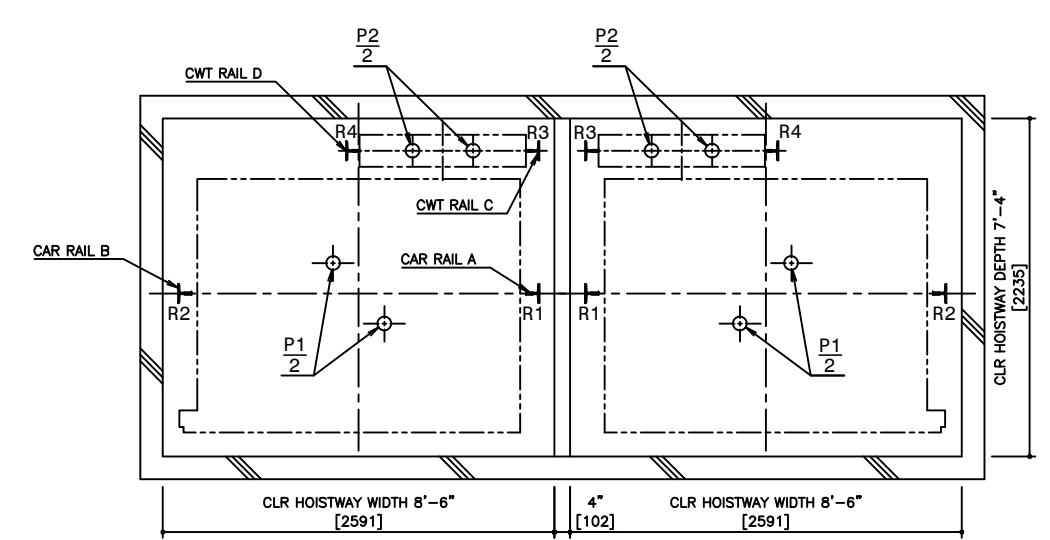

PIT PLAN
WITHOUT CWT SAFETY

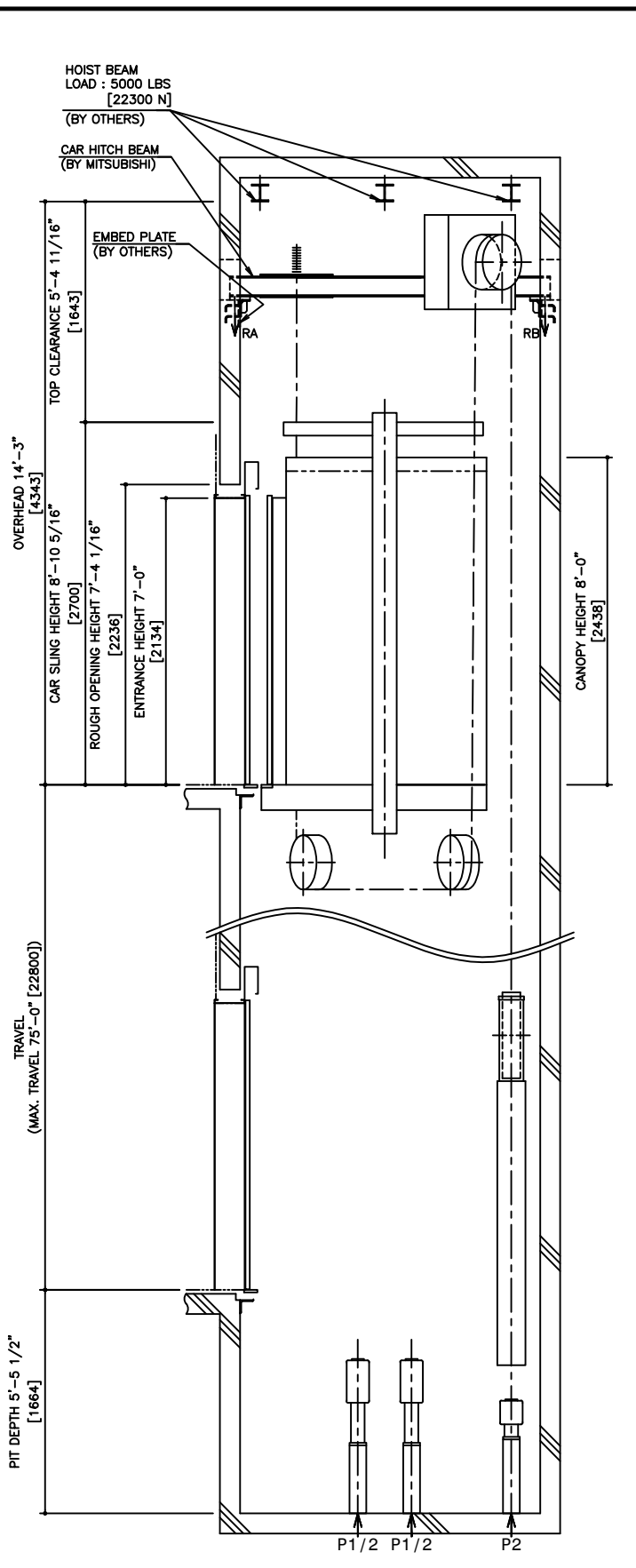

HOISTWAY SECTION
WITHOUT CWT SAFETY

SPECIFICATIONS		
SERIES	DIAMOND TRAC	
LOAD	3000 LBS [1350 kg]	
SPEED	200 FPM [60 m/min]	
REGULATION / CODE	ASME A17.1S - 2005	
TRAVEL	MAX. TRAVEL : 75'-0" [22.8 m]	
DOOR TYPE	SS	
GUIDE RAIL	CAR	ZONE 0 TO 2 T127-1/B
	CWT	ZONE 3 & 4 T127-2/B
CWT SAFETY	ZONE 0 TO 2	T127-1/B
	ZONE 3 & 4	T127-2/B
NOT APPLIED		

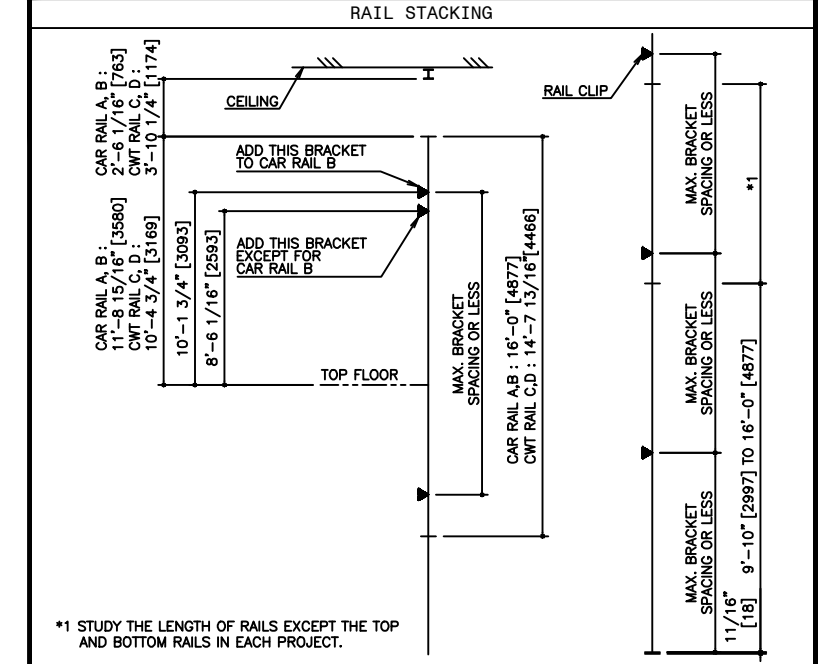

RAIL BRACKET SPACING				
SEISMIC ZONE (RAIL SIZE)	ZONE 0 TO 2 (T127-1/B)		ZONE 3 & 4 (T127-2/B)	
	CAR	CWT	CAR	CWT
RAIL BRACKET SPACING	13'-9 3/8" [4200]	13'-11 5/16" [4250]	12'-11 11/16" [3700]	12'-1 11/16" [3700]

RAIL REACTION LOAD				
SEISMIC ZONE (RAIL SIZE)	CAR RAIL A, B		CWT RAIL C, D	
	F1X	F1Y	F1X	F1Y
ZONE 0 TO 2 (T127-1/B)	1400 LBS [6000 N]	700 LBS [3000 N]	1500 LBS [6500 N]	800 LBS [3300 N]
ZONE 3 & 4 (T127-2/B)	2700 LBS [11900 N]	1400 LBS [6000 N]	3000 LBS [13000 N]	1500 LBS [6500 N]

CAR HITCH BEAM LOAD			
STATIC LOAD		DYNAMIC LOAD	
RA	RB	RA	RB
3900 LBS [17000 N]	1200 LBS [5000 N]	7700 LBS [34000 N]	2100 LBS [9000 N]

PIT REACTION LOAD						
SEISMIC ZONE (RAIL SIZE)	RAIL REACTION LOAD				BUFFER REACTION LOAD	
	R1	R2	R3	R4	P1	P2
ZONE 0 TO 2 (T127-1/B)	11000 LBS [49000 N]	10400 LBS [47000 N]	9800 LBS [43000 N]	6200 LBS [28000 N]	36200 LBS [161000 N]	30200 LBS [134000 N]
ZONE 3 & 4 (T127-2/B)	11400 LBS [51000 N]	10800 LBS [48000 N]	10000 LBS [45000 N]	6800 LBS [30000 N]		

POWER FEEDER DATA 1CAR											
MOTOR	STANDARD VOLTAGE 208V				STANDARD VOLTAGE 480V				HEAT EMISSION		
	FLU [A]	FLAcc [A]	BREAKER IN CONTROL PANEL [A]	CURRENT [A]	FLU [A]	FLAcc [A]	BREAKER IN CONTROL PANEL [A]	POWER SUPPLY CAPACITY [kVA]	HOISTWAY (EXCEPT CAR LIGHTING) [BTU/H]	CONTROL PANEL ROOM [W]	
[HP] [kW]	40	69	50	18	30	30	9	1710	500	3750	1100

POWER CURRENT CORRESPONDING TO LOCAL SUPPLY VOLTAGE (FLU or FLAcc) [A]
 = EACH CURRENT (FLU or FLAcc) [A] x STANDARD VOLTAGE (E1 or E2) [V]
 LOCAL SUPPLY VOLTAGE (E) [V]

DISCLAIMER:
 THESE CAD DRAWINGS SHOULD BE USED FOR REFERENCE ONLY. MEUS DISCLAIMS ALL RESPONSIBILITY FOR ANY REPRODUCTION, MODIFICATION, DISTRIBUTION OR INTEGRATION OF THESE CAD DRAWINGS INTO OTHER ARCHITECTURAL AND STRUCTURAL DRAWINGS. MEUS MARKETS NO WARRANTIES OF ANY KIND WITH RESPECT TO THE ACCURACY OR COMPLETENESS OF THESE CAD SCHEMATIC DRAWINGS FOR ANY PURPOSE. MEUS HEREBY EXPRESSLY DISCLAIMS ALL WARRANTIES, EXPRESSED OR IMPLIED, INCLUDING THE IMPLIED WARRANTIES OF MERCHANTABILITY AND FITNESS FOR A PARTICULAR PURPOSE.
 Copyright (c) 2005 Mitsubishi Electric & Electronic USA, Inc. All rights reserved.

NOTE :
 WHEN THE CANOPY HEIGHT IS CHANGED FROM THE DIMENSION ON THIS DRAWING, OVERHEAD AND THE BRACKET SPAN FOR UPPER RAILS SHALL BE CHANGED AS WELL.

NO.	DATE	BY	REVISIONS
-	02/13/07	-	CREATED DRAWING

PROJECT:	-
ELEV. NO.:	-
DWG. TITLE:	-
ADMIN. NO.:	-
DWG. NO.:	EZ-B-0034
REV.	



SCALE : 1/50

NOT TO BE USED FOR CONSTRUCTION