

HOISTWAY PLAN
WITHOUT CWT SAFETY

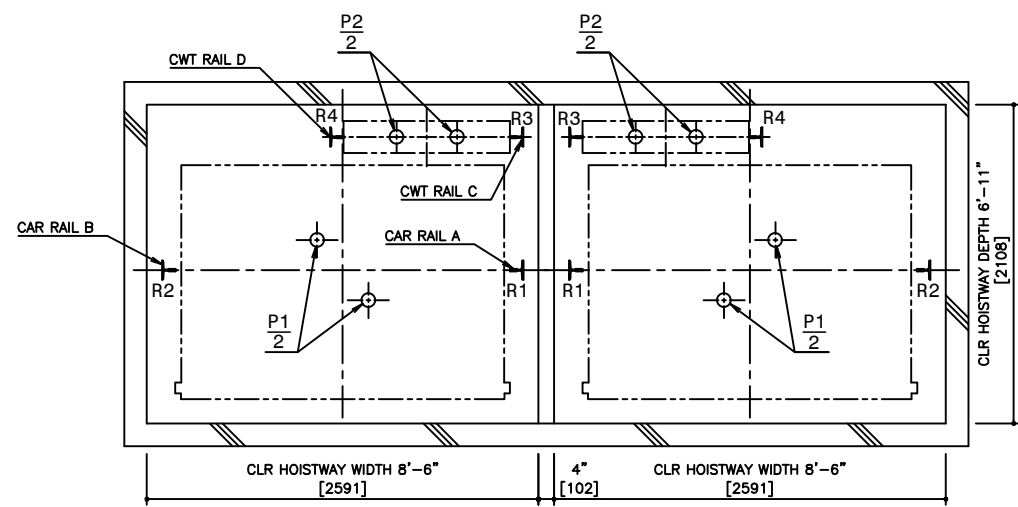

PIT PLAN
WITHOUT CWT SAFETY

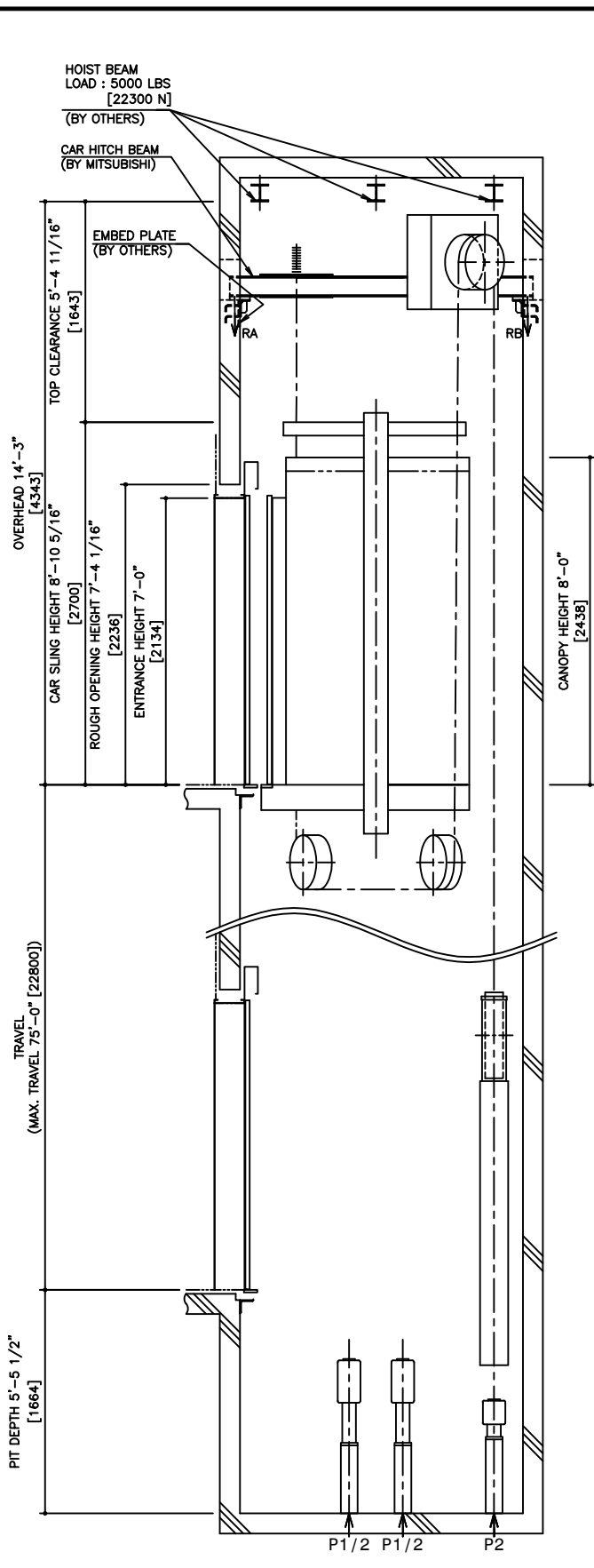

HOISTWAY SECTION
WITHOUT CWT SAFETY

SPECIFICATIONS		
SERIES	DIAMOND TRAC	
LOAD	2500 LBS [1150 kg]	
SPEED	200 FPM [60 m/min]	
REGULATION / CODE	ASME A17.1S - 2005	
TRAVEL	MAX. TRAVEL : 75'-0" [22.8 m]	
DOOR TYPE	CO	
GUIDE RAIL	CAR	ZONE 0 TO 2 T127-1/B
	CWT	ZONE 3 & 4 T127-2/B
CWT SAFETY	ZONE 0 TO 2	T127-1/B
	ZONE 3 & 4	T127-2/B
NOT APPLIED		

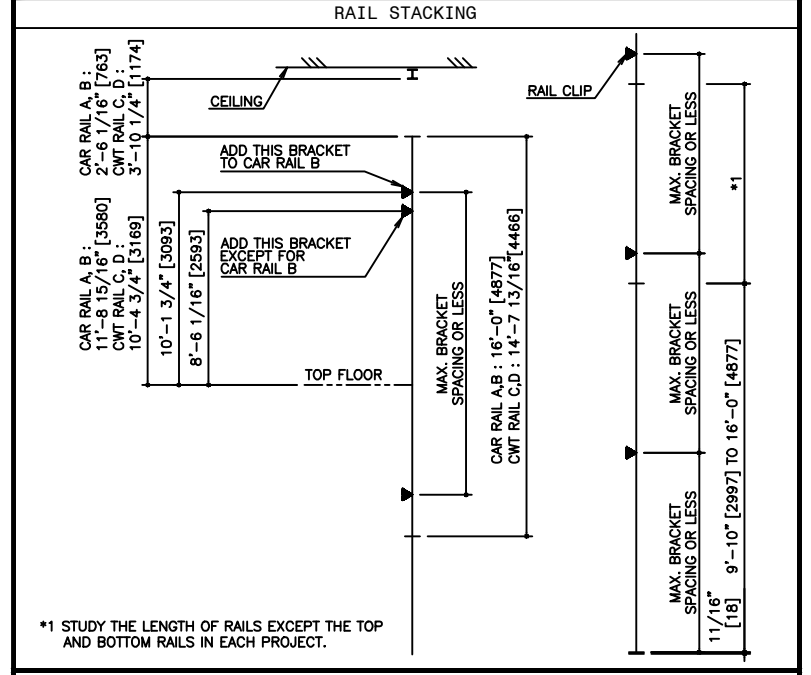

RAIL BRACKET SPACING				
SEISMIC ZONE (RAIL SIZE)	ZONE 0 TO 2 (T127-1/B)		ZONE 3 & 4 (T127-2/B)	
	CAR	CWT	CAR	CWT
RAIL BRACKET SPACING	14'-7 3/16" [4450]	13'-11 5/16" [4250]	12'-11 1/16" [3700]	12'-1 11/16" [3700]

SEISMIC ZONE (RAIL SIZE)	RAIL REACTION LOAD			
	CAR RAIL A, B		CWT RAIL C, D	
	F1X	F1Y	F1X	F1Y
ZONE 0 TO 2 (T127-1/B)	1400 LBS [6200 N]	700 LBS [3100 N]	1500 LBS [6700 N]	800 LBS [3400 N]
ZONE 3 & 4 (T127-2/B)	2800 LBS [12400 N]	1400 LBS [6200 N]	3000 LBS [13400 N]	1500 LBS [6700 N]

CAR HITCH BEAM LOAD			
STATIC LOAD		DYNAMIC LOAD	
RA	RB	RA	RB
3900 LBS [17000 N]	1200 LBS [5000 N]	7500 LBS [33000 N]	2100 LBS [9000 N]

SEISMIC ZONE (RAIL SIZE)	RAIL REACTION LOAD				BUFFER REACTION LOAD	
	R1	R2	R3	R4	P1	P2
ZONE 0 TO 2 (T127-1/B)	10900 LBS [49000 N]	10300 LBS [46000 N]	9400 LBS [42000 N]	6100 LBS [28000 N]	36200 LBS [161000 N]	31100 LBS [139000 N]
ZONE 3 & 4 (T127-2/B)	11300 LBS [51000 N]	10700 LBS [48000 N]	9800 LBS [44000 N]	6500 LBS [29000 N]		

POWER FEEDER DATA 1CAR										
MOTOR	STANDARD VOLTAGE 208V				STANDARD VOLTAGE 480V				HEAT EMISSION	
	FLU [A]	FLAcc [A]	BREAKER IN CONTROL PANEL [A]	CURRENT [A]	FLU [A]	FLAcc [A]	BREAKER IN CONTROL PANEL [A]	POWER SUPPLY CAPACITY [kVA]	HOISTWAY (EXCEPT CAR LIGHTING) [BTU/Hr]	CONTROL PANEL ROOM [W]
9.5 [HP] / 7.1 [kW]	34	58	40	15	26	20	8	1540	450	3240 / 950

POWER CURRENT CORRESPONDING TO LOCAL SUPPLY VOLTAGE (FLU OR FLAcc) [A]
 = EACH CURRENT (FLU OR FLAcc) [A] x STANDARD VOLTAGE (E1 OR E2) [V]
 LOCAL SUPPLY VOLTAGE (E) [V]

DISCLAIMER:
 THESE CAD DRAWINGS SHOULD BE USED FOR REFERENCE ONLY. MEUS DISCLAIMS ALL RESPONSIBILITY FOR ANY REPRODUCTION, MODIFICATION, DISTRIBUTION OR INTEGRATION OF THESE CAD DRAWINGS INTO OTHER ARCHITECTURAL AND STRUCTURAL DRAWINGS. MEUS MARKETS NO WARRANTIES OF ANY KIND WITH RESPECT TO THE ACCURACY OR COMPLETENESS OF THESE CAD SCHEMATIC DRAWINGS FOR ANY PURPOSE. MEUS HEREBY EXPRESSLY DISCLAIMS ALL WARRANTIES, EXPRESSED OR IMPLIED, INCLUDING THE IMPLIED WARRANTIES OF MERCHANTABILITY AND FITNESS FOR A PARTICULAR PURPOSE.
 Copyright (c) 2005 Mitsubishi Electric & Electronic USA, Inc. All rights reserved.

NOTE :
 WHEN THE CANOPY HEIGHT IS CHANGED FROM THE DIMENSION ON THIS DRAWING, OVERHEAD AND THE BRACKET SPAN FOR UPPER RAILS SHALL BE CHANGED AS WELL.

NO.	DATE	BY	REVISIONS
-	02/13/07	-	CREATED DRAWING

PROJECT: -
 ELEV. NO.: -
 DWG. TITLE: -
 ADMIN. NO.: -
 DWG. NO.: EZ-B-0010
 REV.:

MITSUBISHI
 ELEVATORS & ESCALATORS

DIAMOND TRAC

SCALE : 1/50

NOT TO BE USED FOR CONSTRUCTION